

**2022
SCIENCE**

Total marks : 80

Time : 3 hours

General instructions:

- i) Approximately 15 minutes is allotted to read the question paper and revise the answers. The question paper consists of 35 questions in 5 categories.
- ii) All questions are compulsory in 1 and 2 marks questions. General choice has been given in 3 and 5 marks questions.
- iii) Internal choice has been provided in some questions. A student has to attempt only one of the alternatives in such questions.
- iv) Marks allocated to every question are indicated against it.
- v) Alternate questions for the visually impaired students are provided in some questions. **Only the visually impaired students have to attempt such alternate questions.**

N.B: Check to ensure that all pages of the question paper are complete as indicated on the top left side.

1. Choose the correct answer from the given alternatives:

- (a) $\text{CaCO}_3 \rightarrow \text{CaO} + \text{CO}_2$
The above reaction is an example of a 1
- | | |
|-----------------------------|-----------------------------------|
| (i) combination reaction | (ii) decomposition reaction |
| (iii) displacement reaction | (iv) double-displacement reaction |
- (b) The pH of pure water is 1
- | | |
|-----------|----------|
| (i) 1.2 | (ii) 2.2 |
| (iii) 7.4 | (iv) 10 |
- (c) Brass is an alloy of 1
- | | |
|---------------------|----------------------|
| (i) copper and zinc | (ii) copper and tin |
| (iii) lead and tin | (iv) copper and lead |
- (d) In a homologous series, the successive compounds differ by _____ 1
units.
- | | |
|------------------------|------------------------|
| (i) -CH | (ii) -CH ₂ |
| (iii) -CH ₃ | (iv) -C ₂ H |
- (e) Which of the following is a sexually transmitted disease? 1
- | | |
|--------------------|--------------|
| (i) Gonorrhoea | (ii) Malaria |
| (iii) Tuberculosis | (iv) Rabies |
- (f) Which of the following plant did Mendel use for his experiment on the inheritance of traits? 1
- | | |
|----------------|-----------------|
| (i) Wheat | (ii) Sunflower |
| (iii) Hibiscus | (iv) Garden pea |

- (g) Rainbow appearing in the sky after rain is caused by 1
 (i) refraction of light (ii) reflection of light
 (iii) tyndall effect (iv) dispersion of light
- (h) Joule's law of heating is given by the equation 1
 (i) $H=IRt$ (ii) $H=IRt^2$
 (iii) $H=I^2Rt$ (iv) $H=IR^2t$
- (i) The main constituent of biogas is 1
 (i) carbon dioxide (ii) methane
 (iii) hydrogen sulphide (iv) hydrogen
- (j) The important message conveyed by the "Chipko Movement" is 1
 (i) to involve the community in forest conservation efforts
 (ii) to ignore the community in forest conservation efforts
 (iii) to cut down forest tress for developmental activities
 (iv) to give government agencies the unquestionable right to order destruction of tress in forest

Answer the following questions in one word or one sentence:

2. What is a neutralization reaction? 1
3. Name any two noble gases. 1
4. What is meant by a reflex arc? 1
5. Define power of accommodation of human eye. 1
6. What are renewable sources of energy? 1

Answer the following questions in about 20-30 words:

7. What is reactivity series? Name the most reactive metal and the least reactive metal. 1+1=2
8. Mention two important functions of transpiration in plants. 2
9. Write any two changes that are common to both boys and girls during puberty. 1+1=2
10. What are fossils? Give one example. 1+1=2
11. State the two laws of refraction of light. 2

Answer any 10 questions from the following questions (12 to 26) in about 40-60 words:

12. Translate the following statements into chemical equations and then balance them:
 (i) Hydrogen gas combines with nitrogen to form ammonia
 (ii) Barium chloride reacts with aluminium sulphate to give aluminium chloride and a precipitate of barium sulphate. 1+2=3

13. Balance the following chemical equations:
(i) $\text{HNO}_3 + \text{Ca}(\text{OH})_2 \rightarrow \text{Ca}(\text{NO}_3)_2 + \text{H}_2\text{O}$
(ii) $\text{BaCl}_2 + \text{H}_2\text{SO}_4 \rightarrow \text{BaSO}_4 + \text{HCl}$
(iii) $\text{Fe} + \text{H}_2\text{O} \rightarrow \text{Fe}_3\text{O}_4 + \text{H}_2$ **3**

Alternate question for the visually impaired students:

What are exothermic and endothermic reactions? Give one example of each.
($1\frac{1}{2}+1\frac{1}{2}=3$)

14. Write three uses of baking soda. **3**
15. Describe any three methods to prevent corrosion. **3**
16. What are saturated and unsaturated hydrocarbons? Give an example each. **3**
17. a. Name any two plant hormones and write its function. **1+2=3**
Or
b. Name any two hormones in human beings and write its function.
18. Draw the structure of neuron. Label the following parts:
(i) dendrite (ii) axon (iii) nerve ending (iv) nucleus **1+2=3**

Alternate question for the visually impaired students:

Identify the parts of neuron where:

- (i) information is acquired
(ii) information travels as an electrical impulse
(iii) the impulses are converted into chemical signal for onward transmission. **(3)**
19. Differentiate between acquired traits and inherited traits with an example. **3**
20. a. An object 4 cm in size is placed at 25 cm in front of a concave mirror of focal length 15 cm. At what distance from the mirror should a screen be placed in order to obtain a sharp image? Find the nature and the size of the image.
Or **3**
b. An object 5 cm in length is placed at a distance of 20 cm in front of a convex mirror of radius of curvature 30 cm. Find the position of the image, its nature and size.

Alternate question for the visually impaired students:

Write any three uses of concave mirrors. **(3×1=3)**

21. a. In the circuit diagram shown in the figure, suppose the resistors R_1 , R_2 and R_3 have the values 5Ω , 10Ω , 30Ω , respectively, which have been connected to a battery of 12 V. Calculate (a) the current through each resistor, (b) the total current in the circuit, and (c) the total circuit resistance.

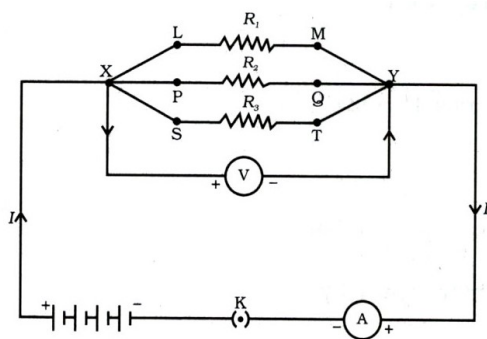

Or

3

- b. An electric iron consumes energy at a rate of 840 W when the heating is at the maximum rate and 360 W when the heating is at the minimum. The voltage is 220V. What are the current and the resistance in each case?

Alternate question for the visually impaired students:

Mention three factors on which the resistance of a conductor depends. (3×1=3)

22. What is a circuit diagram? Mention two advantages of parallel connection over series connection. 3
23. Write three properties of magnetic field lines around a bar magnet. 3
24. Mention three disadvantages of nuclear power generation. 3
25. What are fossil fuels? Give two disadvantages of using fossil fuels. 1+2=3
26. What are the problems caused by the non-biodegradable wastes that humans generate? Give three points. 3

Answer any 5 questions from the following questions (27 to 35) in about 70-100 words:

27. Describe the process of electrolytic refining of copper with a labelled diagram. 3+2=5

Alternate question for the visually impaired students:

Explain malleability and ductility with examples. Explain why sodium is kept immersed in kerosene oil. (1½+1½+2=5)

28. Explain Newlands' Law of Octaves. What were the limitations of the Law of Octaves? 2+3=5
29. a. Describe the structure and functioning of a nephron with the help of a labelled diagram.

Or

3+2=5

- b. Explain the respiratory system in humans with the help of a labelled diagram.

Alternate question for the visually impaired students:

Explain the role of saliva and bile juice in digestion of food. Where does complete digestion take place? (2+2+1=5)

30. Draw a labelled diagram of the longitudinal section of a flower. Explain any three parts of a flower. **2+3=5**

Alternate question for the visually impaired students:

Explain the terms germination, self-pollination and cross-pollination. Name any two pollinating agents. (3+2=5)

31. Explain the refraction of light through a rectangular glass slab with the help of a diagram. **3+2=5**

Alternate question for the visually impaired students:

- a. Define power of a lens. Give its S.I unit.
- b. Which type of lens is known as positive lens and negative lens?
- c. Give an example of an optical instrument where a convex lens is used. (2+2+1=5)

32. a. (i) What is myopia? Where is the image formed for a myopic eye?
(ii) What are its causes?
(iii) How can myopia be corrected?
Or **2+2+1=5**
- b. (i) What is hypermetropia? Where is the image formed for a hypermetropic eye?
(ii) What are its causes?
(iii) How can hypermetropia be corrected?

33. Explain the practical applications of heating effect of electric current in an electric bulb and a fuse. **2½+2½=5**

34. a. Draw a schematic diagram of the common domestic circuit. Mention the three wires, with their colour, used in the circuit.
Or **2+3=5**
- b. With the help of a labelled diagram, explain the working of an electric motor.

Alternate question for the visually impaired students:

- (i) What are the two safety measures commonly used in electric circuits and appliances?
- (ii) What precautions should be taken to avoid the overloading of domestic electric circuits? (2+3=5)

35. 'Increase in demand for energy has environmental consequences.' Suggest five steps to reduce energy consumption. **5**
